

# CSM-Fab, Inc.

PO Box 448  
 5089 Rt. 60  
 Ceredo, WV 25507-0448  
 Phone: (304)429-6918  
 Fax: (304)429-6919

## Duct Construction Standards for TDC 6" WG Pressure

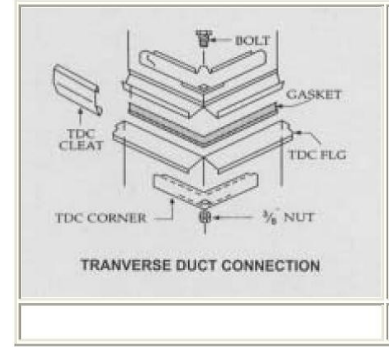
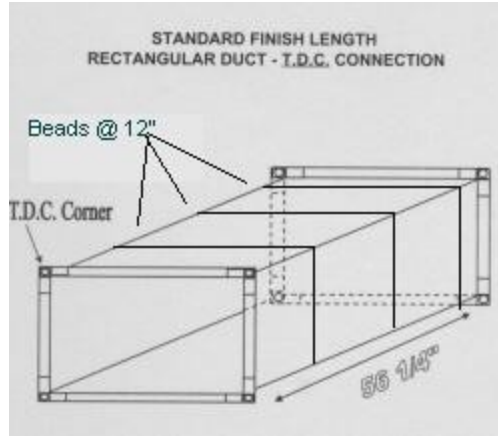

### CSM-Fab, Inc.

manufactures lined and unlined HVAC Duct from Galvanized metal, Stainless Steel, Paint Grip, aluminum and carbon steel according to SMACNA Standards in our union facility. All rectangular duct is fabricated with stiffening beads using state of the art equipment.

All 56&1/4" rectangular duct is fabricated with TDC seams formed directly into the metal to avoid leakage with TDC corners installed.

All duct and fittings are fabricated with Pittsburgh or welded as per your specifications and we can accommodate most any size of duct. All Fittings are fabricated in accordance with SMACNA standards with all accessories (TDC corners, Vane & Rail, etc.. Installed all nuts, bolts, gasket, and Cleat included).

6" TDC		RECTANGULAR DUCT CONSTRUCTION SCHEDULE			
WG		TDC STANDARD DUCTWORK			
POS. OR NEG	DUCT DIMENSION	GAGE	JOINT	CTR	JTR
	10-18	24	TDC	NONE	NONE
	19-24	22	TDC	NONE	NONE
	25-28	20	TDC	NONE	NONE
	29-42	24	TDC	YES	NONE
	49-54	20	TDC	YES	NONE
	55-60	22	TDC	YES	YES
	61-96	20	TDC	YES	YES
	97-UP	18	TDC	YES	YES

TDC = TRANSVERSE DUCT CONN  
 CTR=CENTER TIE ROD  
 JTR = JOINT TIE ROD

